

Butterfly Valves

AGS Series W719



1.0 PRODUCT DESCRIPTION

Available Sizes

- 14 – 60"/DN350 – DN1500

Pipe Material

- Carbon Steel

Maximum Working Pressure

- See section 4 for AWWA Pressure Class

Operating Temperature

- 33°F – 125°F/0.5°C – 52°C

Function

- Used to isolate or regulate flow. Typically used on water services.
- Includes single-offset disc with a replaceable resilient seat for bi-directional service up to full working pressure. Refer to section 3.0 for material specifications.

Pipe Preparation

- Exclusively for use with pipe and Victaulic products which feature ends formed with the Advanced Groove System (AGS), Cut Groove or Roll Groove (see section 7.0 for Reference Materials).

2.0 CERTIFICATION/LISTINGS

- Valve design, materials and testing conform to requirements of AWWA C504.
- See [Submittal 02.06](#): Victaulic Approvals for Potable Water Products - ANSI/NSF 61 and ANSI/NSF 372 for more details.

ALWAYS REFER TO ANY NOTIFICATIONS AT THE END OF THIS DOCUMENT REGARDING PRODUCT INSTALLATION, MAINTENANCE OR SUPPORT.

System No.		Location	
Submitted By		Date	

Spec Section		Paragraph	
Approved		Date	

3.0 SPECIFICATIONS – MATERIAL

Body: Ductile iron conforming to ASTM A-536, grade 65-45-12, fusion bonded epoxy coated.

Disc: Ductile iron conforming to ASTM A-536, grade 65-45-12 fusion bonded epoxy coated.

Seat: 300 Series stainless steel

Disc/Seal:¹

Grade “E” EPDM

EPDM (Green color code). Temperature range –30°F to +230°F/–34°C to +110°C. UL Classified in accordance with ANSI/NSF 61 for cold +73°F/+23°C and hot +180°F/+82°C potable water service and ANSI/NSF 372. NOT RECOMMENDED FOR PETROLEUM SERVICES.

¹ Services listed are General Service Guidelines only. It should be noted that there are services for which these gaskets are not compatible. Reference should always be made to the latest [Victaulic Gasket Selection Guide](#) for specific gasket service guidelines and for a listing of services which are not compatible.

Bearing: Aluminum bronze

Thrust Washer: Bronze

Stem Seals: EPDM

Gasket Retaining Segment: 300 Series stainless steel

Seal Retaining Screw: 300 Series stainless steel

Shaft: 14-48"/DN350-DN1200: 17-4 stainless steel conforming to ASTM A564
54-60"/DN1200-DN1350: 304 stainless steel conforming to ASTM A276

Body Seal: Stainless Steel conforming to ASTM A276, Type 304, or Type 316

Seat Ring: Rubber

Retainer: Stainless Steel conforming to ASTM A276, Type 304, or Type 316

Shaft bearing: PTFE lined

Packing: Rubber EPDM or PTFE

O-Ring: Rubber

Bolt: Stainless Steel conforming to ASTM A193 B8

4.0 DIMENSIONS

Series W719

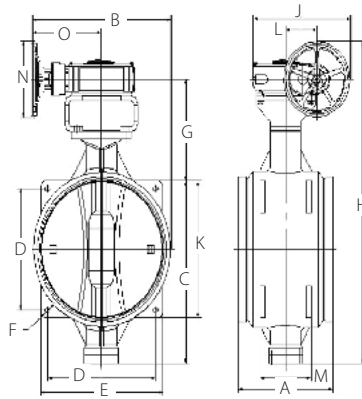

Size inches DN	Pressure/ AWWA Class psi kPa	Dimensions														Weight
		A inches mm	B inches mm	C inches mm	D inches mm	E inches mm	F inches mm	G inches mm	H inches mm	J inches mm	K inches mm	L inches mm	M inches mm	N inches mm	O inches mm	Approx. (Each) lb kg
14 DN350	250B 1724	15.98 406	18.78 477	18.46 469	11.42 290	13.39 340	0.79 20	12.95 329	39.29 998	18.03 458	13.39 340	4.72 120	7.87 200	15.75 400	11.14 283	406 184
16 DN400	250B 1724	15.98 406	23.54 598	20.43 519	13.39 340	15.35 390	0.79 20	12.95 329	38.11 968	14.88 378	15.35 390	4.72 120	7.32 186	15.75 400	14.88 378	470 213
18 DN450	250B 1724	15.98 406	24.69 627	23.27 591	15.12 384	17.09 434	0.79 20	14.25 362	45.39 1153	20.24 514	17.09 434	5.83 148	7.87 200	15.75 400	14.80 376	661 300
20 DN500	250B 1724	17.99 457	25.71 653	25.20 640	16.93 430	18.90 480	0.79 20	14.37 365	47.44 1205	20.24 514	18.90 480	5.83 148	8.66 220	15.75 400	14.80 376	780 354
24 DN600	250B 1724	17.99 457	29.02 737	30.00 762	20.08 510	22.83 580	0.94 24	16.97 431	54.84 1393	22.87 581	22.83 580	7.28 185	9.06 230	15.75 400	16.02 407	1213 550
30 DN750	250B 1724	22.01 559	32.13 816	37.72 958	25.20 640	28.35 720	1.18 30	20.98 533	66.57 1691	22.87 581	28.35 720	7.28 185	11.81 300	15.75 400	16.02 407	2059 934
36 DN900	250B 1724	22.01 559	36.89 937	44.96 1142	30.31 770	33.86 860	1.42 36	24.29 617	77.13 1959	26.06 662	33.86 860	9.06 230	11.81 300	15.75 400	17.76 451	3254 1476
42 DN1050	250B 1724	24.02 610	44.65 1134	51.81 1316	35.43 900	40.16 1020	1.65 42	25.87 657	85.55 2173	34.45 875	40.16 1020	12.40 315	13.39 340	15.75 400	22.36 568	4899 2222
48 DN1200	250B 1724	25.98 660	47.68 1211	57.76 1467	40.16 1020	44.88 1140	1.65 42	29.17 741	94.80 2408	34.45 875	44.88 1140	12.40 315	15.75 400	15.75 400	22.36 568	5908 2680
54 DN1350	150B 1034	27.99 711	54.45 1383	65.35 1660	45.67 1160	51.97 1320	2.20 56	31.34 796	104.57 2656	41.42 1052	51.97 1320	16.22 412	16.54 420	15.75 400	25.98 660	9076 4117
60 DN1500	150B 1034	30.00 762	57.68 1465	71.26 1810	50.39 1280	56.69 1440	2.20 56	32.52 826	111.65 2836	41.42 1052	56.69 1440	16.22 412	18.11 460	15.75 400	25.98 660	11184 5073

NOTE

- Additional sizes available. Contact Victaulic.

4.0 DIMENSIONS (Continued)

Flow Characteristics

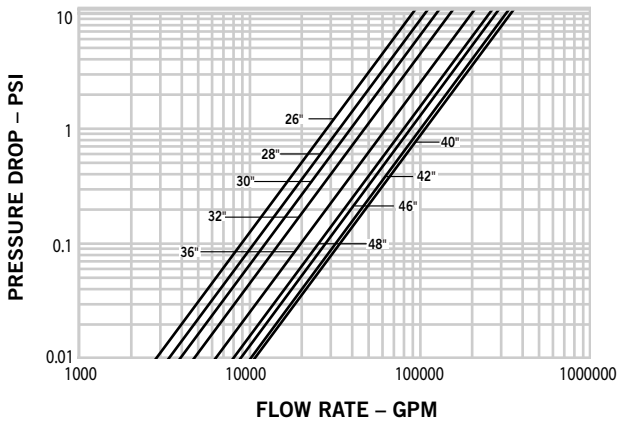

5.0 PERFORMANCE

Series W719

C_v/K_v values for flow of water at +60°F/+16°C with various disc positions are shown in the table below.

Formulas for C_v/K_v values:

$$\Delta P = \frac{Q^2}{C_v^2}$$

$$Q = C_v \times \sqrt{\Delta P}$$

Where:

Q = Flow (GPM)

ΔP = Pressure Drop (psi)

C_v = Flow Coefficient

Size	Cv at Opening Position						
	Cv Value Kv Value						
Nominal	30	40	50	60	70	80	90
inches							
mm							
30	4220	6450	10500	15430	23900	35230	38960
750	3650	5579	9083	13347	20674	30474	33700
36	5010	8250	13400	21390	35130	53560	62600
900	4334	7136	11591	18502	30387	46329	54149
42	8020	15070	23270	31990	50460	75490	87700
1050	6937	13036	20129	27671	43648	65299	75861
48	11520	18280	27660	40290	61230	89080	106240
1200	9965	15812	23926	34851	52964	77054	91898

5.0 PERFORMANCE (Continued)

Torque Values

Size	Breakaway Torque with Valve Seat Downstream of Pressure (in. lb. / N. m.)					
	Differential Pressure					
	0	50	100	150	200	250
Nominal	psi Bar	psi Bar	psi Bar	psi Bar	psi Bar	psi Bar
inches DN	psi Bar	psi Bar	psi Bar	psi Bar	psi Bar	psi Bar
14	1611	5044	7522	10000	12478	14646
DN350	182	570	850	1130	1410	1655
16	2372	6770	10159	13549	16929	19681
DN400	268	765	1148	1531	1913	2224
18	3558	9345	14115	18894	23664	27540
DN450	402	1056	1595	2135	2674	3112
20	3858	11566	17661	23761	29858	34938
DN500	436	1307	1996	2685	3374	3948
24	6283	19053	29177	39292	49416	57460
DN600	710	2153	3297	4440	5584	6493
30	14000	33354	51664	69973	88274	103752
DN750	1582	3769	5838	7907	9975	11724
36	42655	53602	83195	112788	142381	168142
DN900	4820	6057	9401	12745	16089	19000
42	66018	77805	121637	165469	209301	247947
DN1050	7460	8792	13745	18698	23651	28018
48	91504	108920	171000	233088	295212	350920
DN1200	10340	12308	19393	26339	33359	39654
54	135044	156080	245593	335097		
DN1350	15260	17637	27752	37866		
60	165664	200717	315973	419628		
DN1500	18720	22681	35705	47418		

Size	Breakaway Torque with Valve Seat Upstream of Pressure (in. lb. / N. m.)					
	Differential Pressure					
	0	50	100	150	200	250
Nominal	psi Bar	psi Bar	psi Bar	psi Bar	psi Bar	psi Bar
inches DN	psi Bar	psi Bar	psi Bar	psi Bar	psi Bar	psi Bar
14	991	4070	1611	7088	8593	9796
DN350	112	460	631	801	971	1107
16	1451	5460	7531	9611	11681	13124
DN400	164	617	851	1086	1320	1483
18	2301	7664	10770	13867	16965	19168
DN450	260	866	1217	1567	1917	2166
20	2991	9186	12894	16611	20319	23027
DN500	338	1038	1457	1877	2296	2602
24	5593	15549	22168	28779	35389	39938
DN600	632	1757	2505	3252	3999	4513
30	11628	27142	39230	51327	63416	72681
DN750	1314	3067	4433	5800	7166	8213
36	32478	44611	65212	86699	106416	123009
DN900	3670	5041	7369	9797	12025	13900
42	45434	65478	96982	128487	165566	18310
DN1050	5134	7399	10959	14519	18709	21053
48	70620	91053	135265	179478	223743	261575
DN1200	7980	10289	15285	20281	25283	29558
54	100442	133593	200602	267619		
DN1350	11350	15096	22668	30241		
60	126549	172602	259752	335292		
DN1500	14300	19504	29352	37888		

NOTE

- Additional sizes available. Contact Victaulic

5.0 PERFORMANCE (Continued)

Valve Torque Requirements

Source:

These torque values were derived from test data with non-lubricated valves in water at ambient temperatures with EPDM seals. For other material and service conditions, apply a suitable service factor.

Torque Factors:

All torque values are for normal conditions (i.e., the valve is operated at least once a quarter, disc corrosion is expected to be minor, the media is clean and nonabrasive, and the chemical effects upon the elastomer are minor).

Typical Fluid Torque Factors Commonly Used in the Industry:

Water: 1.0

Material Torque Factors:

“E” = 1.0

Cycling Factor:

Torque will typically increase as the valve is cycled. A factor of 1.5 should be applied for the first 5,000 cycles and another 1.5 applied for all additional cycles. The higher number should be used if there is more than one cycle per hour.

Actuation Factor:

There are no actuation safety factors applied. A factor consistent with the consequences of not actuating should be applied. A minimum factor of 1.2 is recommended for directly actuated valves and 1.5 for 3-way assemblies.

Combining Torque Factors:

When multiple torque factors apply, they are combined by multiplying them. Example: For an EPDM seal and a 5,000-cycle factor, the combined factor would be $1.0 \times (1.5) = 1.5$.

NOTES

- Under certain high flow conditions, the hydrodynamic torque can exceed the seating torque. Large butterfly valves are not recommended for use in a free discharge condition, such as filling an empty line with fluid at the full-rated pressure.
- Contact Victaulic for other services.

6.0 NOTIFICATIONS

WARNING

- Victaulic AGS products use a patent-pending groove profile that requires the use of special AGS rolls. AGS products must not be used on pipe that has been grooved using standard grooving rolls.

Failure to use AGS products on AGS grooved pipe could result in serious personal injury, property damage, joint leakage or joint separation.

WARNING



- Read and understand all instructions before attempting to install, remove, adjust, or maintain any Victaulic piping products.
- Depressurize and drain the piping system before attempting to install, remove, adjust, or maintain any Victaulic piping products.
- Wear safety glasses, hardhat, and foot protection.

Failure to follow these instructions could result in death or serious personal injury and property damage.

NOTICE

- **DO NOT** install valves with the disc in the full-open position. Make sure no part of the disc protrudes beyond the end of the valve body.
- Use **ONLY** grooved-end, NPS carbon steel pipe with Victaulic Butterfly Valves. **DO NOT** use plain-end NPS pipe or grooved cast ductile iron pipe.
- To prevent valves from rotating in the system, Victaulic recommends installing butterfly valves with at least one Victaulic rigid coupling. If two Victaulic flexible couplings are used, additional support may be required to prevent the valve from rotating. Refer to the instructions, supplied with the couplings and butterfly valves, for proper installation.

7.0 REFERENCE MATERIALS

[05.01: Seal Selection Guide](#)

[16.11: AGS Vic-Ring® Systems](#)

[20.05: AGS Fittings](#)

[25.09: AGS Roll Groove Data](#)

[26.01: Victaulic Design Data](#)

[I-100: Victaulic Field Installation Handbook](#)

[I-107: Victaulic Installation Instructions - Style 107N QuickVic™ Installation-Ready™ Rigid Coupling](#)

[I-W07/W77: AGS Installation](#)

User Responsibility for Product Selection and Suitability

Each user bears final responsibility for making a determination as to the suitability of Victaulic products for a particular end-use application, in accordance with industry standards and project specifications, and the applicable building codes and related regulations as well as Victaulic performance, maintenance, safety, and warning instructions. Nothing in this or any other document, nor any verbal recommendation, advice, or opinion from any Victaulic employee, shall be deemed to alter, vary, supersede, or waive any provision of Victaulic Company's standard conditions of sale, installation guide, or this disclaimer.

Intellectual Property Rights

No statement contained herein concerning a possible or suggested use of any material, product, service, or design is intended, or should be construed, to grant any license under any patent or other intellectual property right of Victaulic or any of its subsidiaries or affiliates covering such use or design, or as a recommendation for the use of such material, product, service, or design in the infringement of any patent or other intellectual property right. The terms "Patented" or "Patent Pending" refer to design or utility patents or patent applications for articles and/or methods of use in the United States and/or other countries.

Note

This product shall be manufactured by Victaulic or to Victaulic specifications. All products to be installed in accordance with current Victaulic installation/assembly instructions. Victaulic reserves the right to change product specifications, designs and standard equipment without notice and without incurring obligations.

Installation

Reference should always be made to the Victaulic installation handbook or installation instructions of the product you are installing. Handbooks are included with each shipment of Victaulic products, providing complete installation and assembly data, and are available in PDF format on our website at www.victaulic.com.

Warranty

Refer to the Warranty section of the current Price List or contact Victaulic for details.

Trademarks

Victaulic and all other Victaulic marks are the trademarks or registered trademarks of Victaulic Company, and/or its affiliated entities, in the U.S. and/or other countries.