

## Series 798 Double Pneumatic Actuator

### PRODUCT DESCRIPTION



The Victaulic Series 798 Double Pneumatic Actuator (DPA) is a pneumatically actuated device that requires two separate pneumatic activations in order to actuate a preaction fire protection valve. Series 798 can be used with the Series 758 FireLock Preaction valve or the Series 769 FireLock NXT™ Preaction Valve for double interlock pneumatic/pneumatic systems. Air pressure loss in both the pilot line and system line are required to activate the DPA. Double interlock systems using the Series 798 DPA do not require an electric release panel and provide an added level of security in areas with limited or unreliable electric power. The Series 798 DPA allows the sprinkler and pilot line systems to operate with a low air or gas pressure of 10 psi/69 kPa, regardless of the supply water pressure. The Series 798 is designed to actuate at 7 psi/48 kPa for both the pilot and sprinkler system. When air pressures have decayed to 7 psi/48 kPa in both systems the 798 will actuate, thus releasing the pressure from the piston charge line and actuating the sprinkler actuated valve in its intended manner.

The low pressure required in the pilot and sprinkler systems allows both systems to have a very low moisture content while the 7 psi/48 kPa trip point will allow water to enter the sprinkler system and reach a greater number of heads more rapidly. The patented single unit design operates as a pneumatic pneumatic double interlock device and greatly simplifies set up.

The Series 798 DPA is rated to 300 psi/2065 kPa working pressure and is tested and approved to be used on Victaulic Series 769 FireLock NXT Preaction valves or Series 758 fire protection valves.

### DIMENSIONS

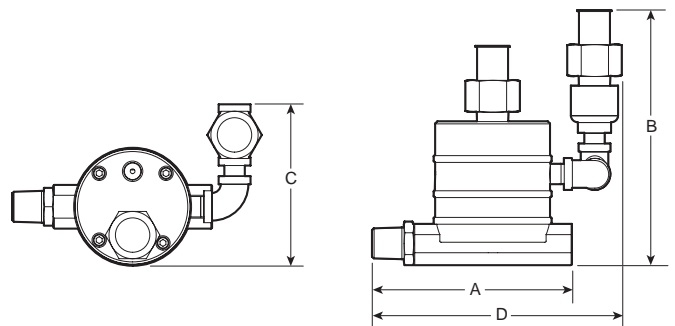

Nominal Size Inches/mm	Actual Outside Diameter Inches/mm	Dimensions – Inches/mm				Aprx. Weight Each Lbs./kg
		A	B	C	D	
1/2	0.840	5.30	6.70	4.30	6.6	2.5
15	21.3	135	170	109	1680	1.1

### MATERIAL SPECIFICATIONS

**Lower Chamber:** Durable cast bronze

**Middle and Upper Chambers:** Brass per UNS C36000

**Internal Components:** Brass per UNS C36000

**Seals:** EPDM

**Fasteners:** Stainless Steel per UNS C30000

**Springs:** Stainless steel

**Strainer:** Brass per UNS C36000 and Stainless Steel per UNS C30000

**Eyelets:** Brass per UNS C36000

**O-ring:** Buna N

**Diaphragms:** EPDM

## OPERATION

The Series 798 Double-Pneumatic Actuator is a pneumatically actuated valve used to trigger the operation of Victaulic Series 769 FireLock NXT Preaction valves or Series 758 Preaction Valves with double-interlock pneumatic/pneumatic trim.

Diaphragms separate the double-pneumatic actuator into four chambers. The upper and upper-middle chambers control the double pneumatic actuator's activation, while the lower and lower-middle chambers act as the water control valve.

During charging, the sprinkler system and pilot air pressures feed into the upper and upper-middle chambers of the double-pneumatic actuator. Pulling up on the two auto vents, located on the double-pneumatic actuator, sets the air pressure in these chambers.

The system pressure in the upper chamber exerts closing pressure on the upper-middle diaphragm through a piston. At the same time, pilot air pressure on the upper-middle chamber exerts closing pressure on the middle diaphragm. These forces close the water path of the lower-middle chamber.

When the piston charge line of the control valve is open, water enters the lower chamber of the double-pneumatic actuator; this water flows to the lower-middle chamber through the inlet. The lower-middle diaphragm assembly traps water in the lower-middle chamber. Pilot air pressure in the upper-middle chamber, along with system air pressure in the upper chamber, holds the lower-middle diaphragm assembly closed.

Since the area of the lower diaphragm is greater than the area of the lower chamber, the lower chamber seals; therefore, no water flows to the actuator's outlet, and the water supply pressure creates a seal.

When pilot air pressure decays to 7 psi/48 kPa, the auto vent's compression spring exerts a force greater than the air pressure in the upper-middle chamber. The auto vent opens, and all air pressure in the upper-middle chamber evacuates. During this condition, the double-pneumatic actuator will not activate, since air pressure in the upper chamber maintains a closing force on the water seal of the lower-middle chamber.

Likewise, if the system air pressure decays to 7 psi/48 kPa, the auto vent's compression spring exerts a force greater than the air pressure in the upper chamber. The auto vent opens, and all air pressure in the upper chamber evacuates. During this condition, the double-pneumatic actuator will not activate, since air pressure in the upper-middle chamber maintains a closing force on the water seal of the lower-middle chamber.

When air pressure in both the pilot line and the system decays to 7 psi/48 kPa, the auto vents operate. During this condition, the closing force on the lower-middle chamber's water seal is removed, and the lower-middle chamber's water pressure releases, which allows the lower diaphragm to lift and water to flow from the double-pneumatic actuator's inlet to the outlet. This water flow releases water pressure from the control valve's piston, allowing the piston to retract. The control valve's clapper opens, and water flows into the sprinkler system.

### **Auto Vent**

After the control valve operates, water enters the airline portion of the trim, which connects to the upper chamber of the double-pneumatic actuator and controls its actuation. If the upper chamber becomes pressurized, the double-pneumatic actuator could close prematurely. Therefore, the Series 748 Ball Check in the trim prevents most of this water from entering the double-pneumatic actuator.

In case the Series 748 Ball Check malfunctions, the auto vent of the double-pneumatic actuator acts as an anti-flood device. When the auto vent opens, the water that enters the double-pneumatic actuator's upper chamber flows through the auto vent faster than it enters the upper chamber. Therefore, pressure does not develop in the upper chamber.

BILL OF MATERIALS	
Item	Description
1	Auto Vent Sleeve (Pilot)
2	Auto Vent Screw (Pilot)
3	Pilot Auto Vent Assembly
4	Auto Vent Sleeve (System)
5	Auto Vent Screw (System)
6	System Auto Vent Assembly
7	Upper Chamber
8	Lower Diaphragm
9	Upper-Middle Chamber
10	Middle Diaphragm
11	Lower-Middle Chamber
12	Lower Diaphragm
13	Strainer Assembly
14	Strainer O-Ring
15	Strainer Screen
16	Lower Chamber

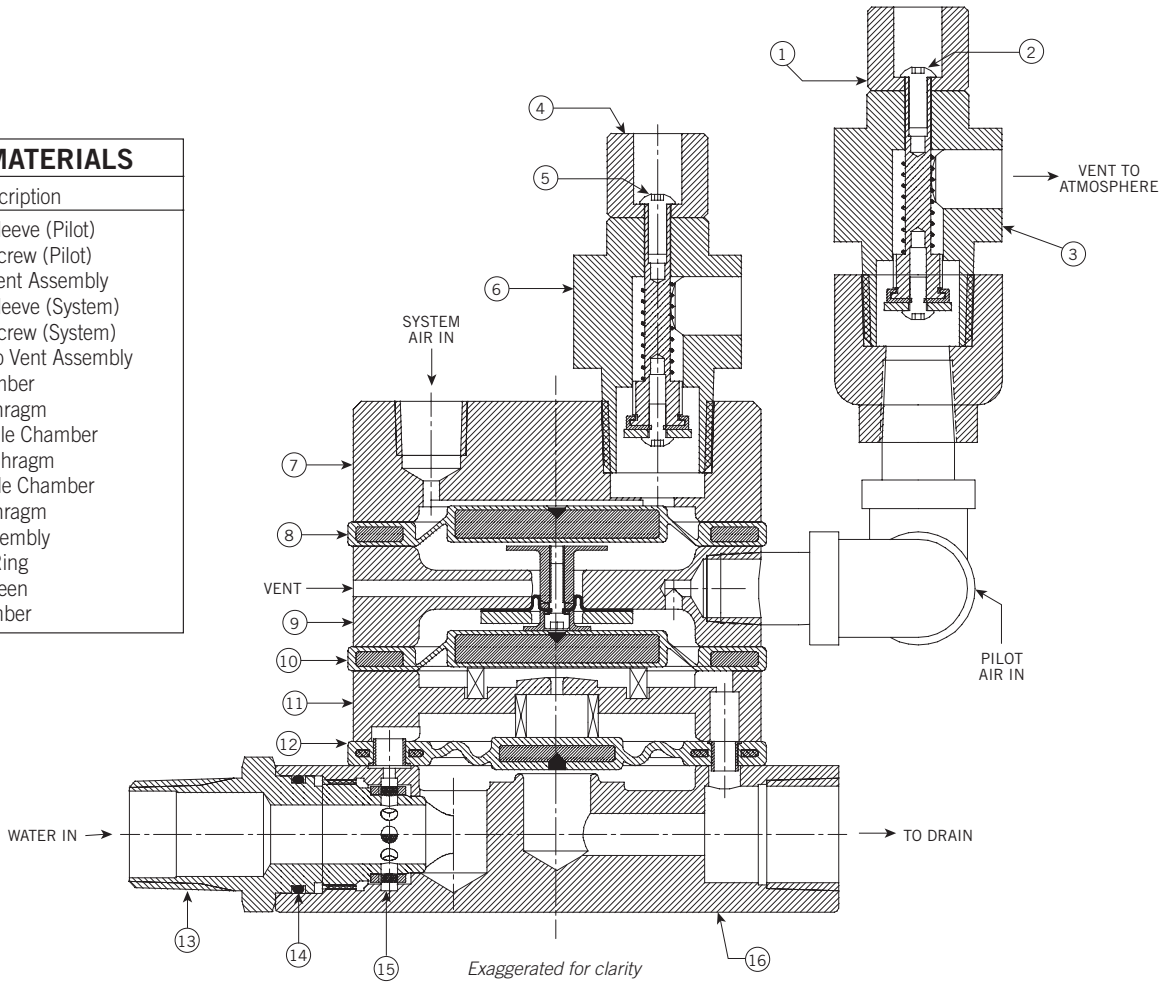

This product shall be manufactured by Victaulic or to Victaulic specifications. All products to be installed in accordance with current Victaulic installation/assembly instructions. Victaulic reserves the right to change product specifications, designs and standard equipment without notice and without incurring obligations.