

Electric/Pneumatic Double Interlock Actuator

Series 767



Approvals/Listings:



See Victaulic Publication 10.01 for more details.

Series 767 introduces a new concept in actuator design, featuring a single trip point for the pneumatic event, regardless of supply water pressure, and an integral electric solenoid. The Series 767 Electric/Pneumatic Double Interlock low pressure actuator is designed to trigger systems using the Series 769 FireLock NXT Praction valve, per 30.82. This new design allows you to set the system without having to activate the solenoid.

This single, compact unit has a 1/2"/15 mm water inlet and is for use on all Series 769 FireLock NXT Praction valves up to 300 psi/2065 kPa. Series 767 includes all the fittings necessary for installation.

Material Specifications:

- **Actuator**

Lower Chamber: Durable castbronze UNS C36000

Middle and Upper Chambers: 360 brass

Internal Components: 360 brass

Seals: EPDM

Fasteners: 316 series stainless steel

Springs: Stainless steel

Electrical: 24V DC Normally Closed

Strainer: 360 Brass and 300 series stainless steel

Eyelets: 360 Brass

O-ring: Buna

Diaphragms: EPDM

- **Solenoid**

Body: Forged Brass

Spring: 300 Series Stainless Steel

Seal: Fluoroelastomer

Diaphragm: Fluoroelastomer

Wiring: 24 VDC

Voltage: 24 VDC

Power Rating: 8.7 Watts

Resistance: 66 Ohms

Current: 364 Amps

Job/Owner

System No.	
Location	

Contractor

Submitted By	
Date	

Engineer

Spec Section	
Paragraph	
Approved	
Date	

Dimensions:

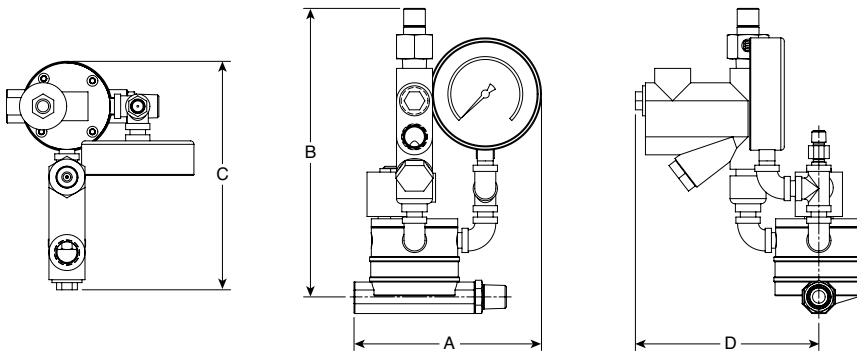

Nominal Size inches mm	Actual Outside Diameter inches mm	Dimensions				Approx. Weight Each lbs. kg
		A inches mm	B inches mm	C inches mm	D inches mm	
1/2 15	0.84 21.3	6.75 171	10.25 260	8.25 210	6.50 165	2.5 1.1

Operation:

The Series 767 Electric/Pneumatic Actuator is a single-unit device used in the actuation of Series 769 Preaction Valves with double-interlock electric/pneumatic trim.

Diaphragms separate the Series 767 into four chambers. The upper and upper-middle chambers control the actuation, while the lower and lower-middle chambers act as the water control valve.

During system charging, air pressure enters the upper-middle chamber of the Series 767. Pulling up on the auto vent, which is located on the Series 767 trim, sets the air pressure in this upper-middle chamber. Water supply pressure from the piston charge line enters the upper chamber, and the normally closed solenoid, which is built into the Series 767, sets this water pressure.

There is no need to activate the solenoid in order to set the system.

The system air pressure in the upper-middle chamber exerts a closing force on the middle chamber of the Series 767. Additionally, the water supply pressure from the piston charge line exerts a closing force on the middle diaphragm through a piston that connects the upper and middle diaphragms. These pressures close the water path of the lower-middle chamber.

When the piston charge line is open, water enters the lower chamber of the Series 767; this water flows to the lower-middle chamber through the inlet. The middle diaphragm traps water in the lower-middle chamber. Supply water pressure in the upper chamber and system air pressure in the upper-middle chamber hold the lower-middle diaphragm assembly closed.

Since the area of the lower diaphragm is greater than the area of the lower chamber, the lower chamber seals; therefore, no water flows to the actuator’s outlet, and the water pressure creates a seal.

When system air pressure decays to 7 psi (45 kPa), the auto vent’s compression spring exerts a force greater than the air pressure in the upper-middle chamber. The auto vent opens, and all air pressure in the upper-middle chamber evacuates. During this condition, the Series 767 will not operate, since the water pressure in the upper chamber maintains a closing force on the water seal of the lower-middle chamber.

Likewise, if there is an electrical detection event, the solenoid on the upper chamber will activate and cause the upper chamber’s water pressure to release. The Series 767 will not operate, since the uppermiddle chamber’s air pressure exerts a closing force on the lower-middle chamber’s water seal.

The Series 767 will actuate only when an electrical detection and loss of system air pressure occur. During this condition, the closing force on the lower-middle diaphragm’s water seal is removed, and the lower-middle chamber’s water pressure releases. This allows the lower diaphragm to lift and water to flow from the Series 767’s inlet to the outlet. This water flow releases water pressure from the control valve’s piston and allows the piston to retract. The control valve’s clapper opens, and water flows into the sprinkler system.

Operation:

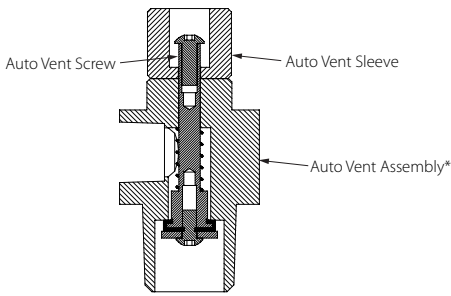

The auto vent, shown above, is located in the trim of the upper- middle chamber.
NOTE: The auto vent is shown in the set position with the sleeve resting on the body and the screw elevated.

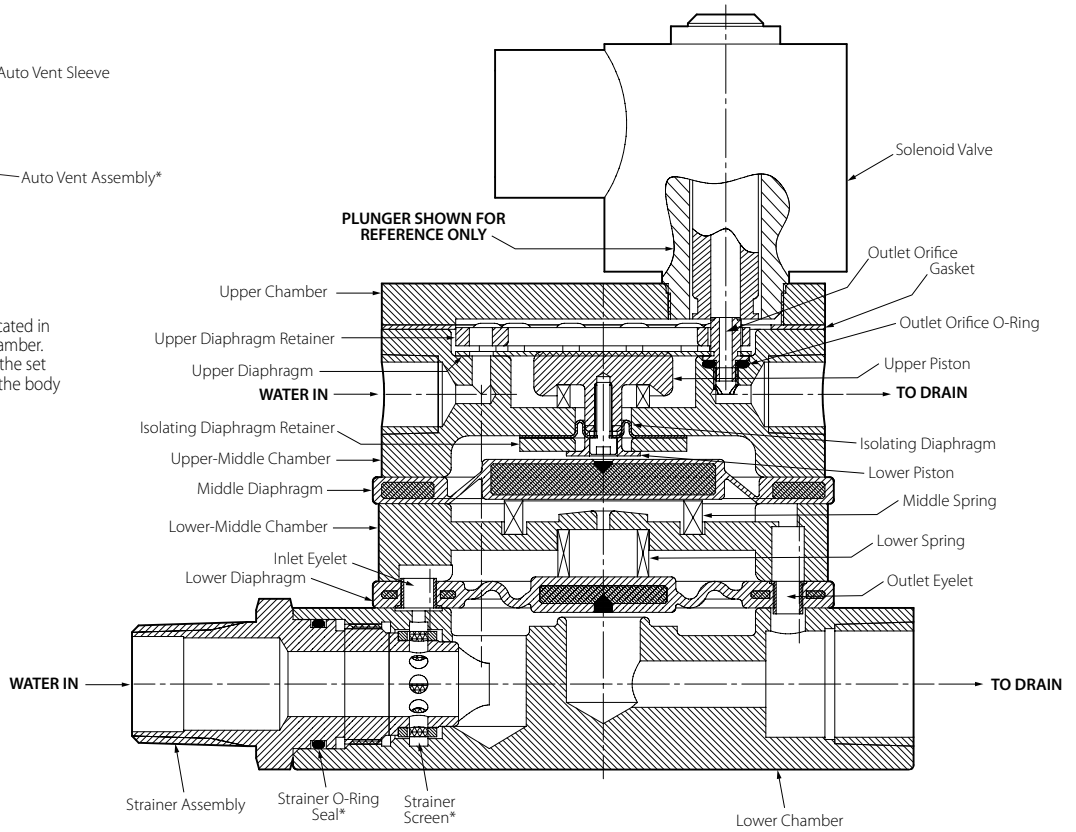

Illustration is exaggerated for clarity

** Denotes components that can be replaced in the field*

Installation

Reference should always be made to the [I-100 Victaulic Field Installation Handbook](#) for the product you are installing. Handbooks are included with each shipment of Victaulic products for complete installation and assembly data, and are available in PDF format on our website at www.victaulic.com.

Warranty

Refer to the Warranty section of the current Price List or contact Victaulic for details.

Note

This product shall be manufactured by Victaulic or to Victaulic specifications. All products to be installed in accordance with current Victaulic installation/assembly instructions. Victaulic reserves the right to change product specifications, designs and standard equipment without notice and without incurring obligations.

Trademarks

Victaulic and Zero-Flex are registered trademarks of Victaulic Company.